

*This form is a summary description of the model entitled “Permutation admissibility in multistage interconnection networks” proposed for the Model Checking Contest @ Petri Nets. Models can be given in several instances parameterized by scaling parameters. Colored nets can be accompanied by one or many equivalent, unfolded P/T nets. Models are given together with property files (possibly, one per model instance) giving a set of properties to be checked on the model.*

## Description

The model describes a  $8 \times 8$  4 stages shuffle-exchange network. In order to ease readability, the net components are grouped in columns similar to the way the switches are arranged in stages. Thus, whole net is represented as a cascade of columns alternating in type of the components being either place or transition. Transitions occur column-wise from the leftmost to the rightmost and in columns from the topmost to the bottommost. It can be easily seen that no token can visit a place more than once. Direction of the arcs indicates the flow of tokens through the net.

Here, we consider the scaling parameter  $N$  as a multiplier for the initial marking in places  $\text{in}(x)$  and  $\text{c5}$ . The figure shows the model when  $N = 1$ .

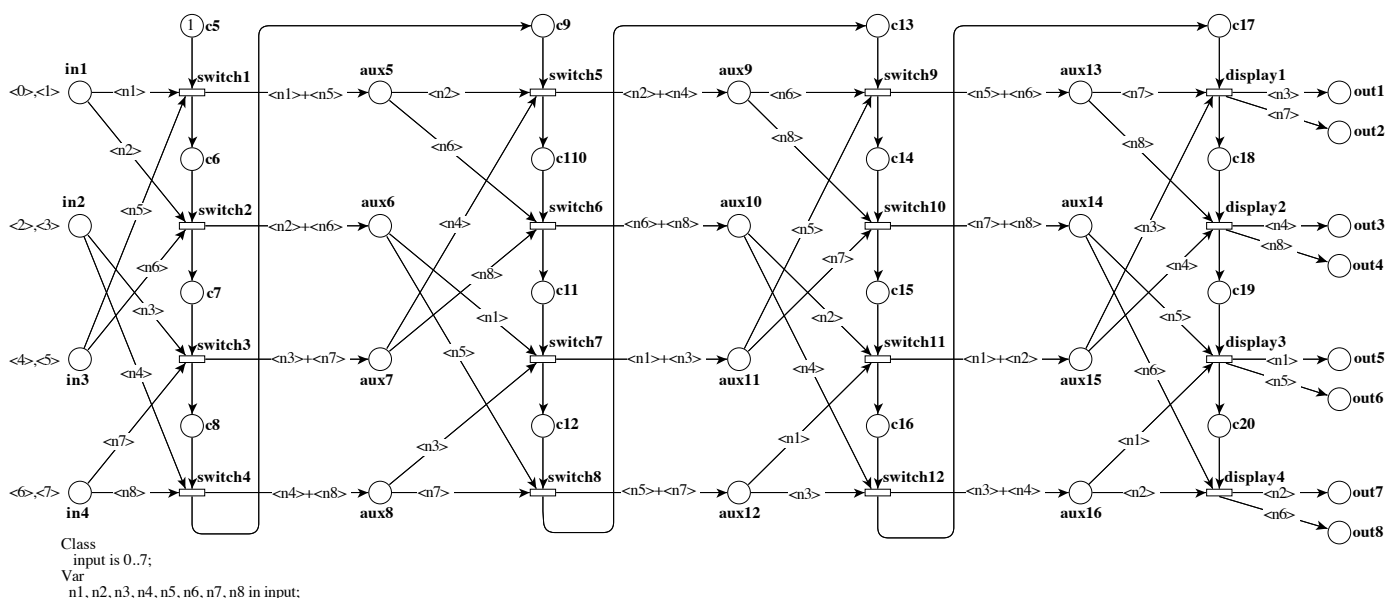

Graphical representation for  $N = 1$

## References

R. Bashirov, F. Kordon, and H. Lort. Exploiting colored Petri nets to decide on permutation admissibility. *Acta Informatica*, 46(1):43–55, February 2009.

## Scaling parameter

Parameter name	Parameter description	Chosen parameter values
N	Multiplier for the marking of places $\text{in}(x)$ and $\text{c5}$	1, 2, 5, 10, 20, 50

## Size of the model

Although the model is parameterized, its size does not depend on parameter values.

number of places: 40  
number of transitions: 16  
number of arcs: 83

## Structural properties

<b>ordinary</b> — all arcs have multiplicity one .....	X
<b>simple free choice</b> — all transitions sharing a common input place have no other input place .....	X (a)
<b>extended free choice</b> — all transitions sharing a common input place have the same input places .....	X (b)
<b>state machine</b> — every transition has exactly one input place and exactly one output place .....	X (c)
<b>marked graph</b> — every place has exactly one input transition and exactly one output transition .....	X (d)
<b>connected</b> — there is an undirected path between every two nodes (places or transitions) .....	✓ (e)
<b>strongly connected</b> — there is a directed path between every two nodes (places or transitions) .....	X (f)
<b>source place(s)</b> — one or more places have no input transitions .....	✓ (g)
<b>sink place(s)</b> — one or more places have no output transitions .....	✓ (h)
<b>source transition(s)</b> — one or more transitions have no input places .....	X (i)
<b>sink transitions(s)</b> — one or more transitions have no output places .....	X (j)
<b>loop-free</b> — no transition has an input place that is also an output place .....	✓ (k)
<b>conservative</b> — for each transition, the number of input arcs equals the number of output arcs .....	X (l)
<b>subconservative</b> — for each transition, the number of input arcs equals or exceeds the number of output arcs .....	X (m)
<b>nested units</b> — places are structured into hierarchically nested sequential units <sup>(n)</sup> .....	X

## Behavioural properties

<b>safe</b> — in every reachable marking, there is no more than one token on a place .....	X (o)
<b>deadlock</b> — there exists a reachable marking from which no transition can be fired .....	✓ (p)
<b>reversible</b> — from every reachable marking, there is a transition path going back to the initial marking .....	X
<b>quasi-live</b> — for every transition $t$ , there exists a reachable marking in which $t$ can fire .....	?
<b>live</b> — for every transition $t$ , from every reachable marking, one can reach a marking in which $t$ can fire .....	?

(a) the net is not ordinary in all its 6 instances (1, 2, 5, 10, 20, and 50).  
(b) the net is not ordinary in all its 6 instances (1, 2, 5, 10, 20, and 50).  
(c) the net is not ordinary in all its 6 instances (1, 2, 5, 10, 20, and 50).  
(d) the net is not ordinary in all its 6 instances (1, 2, 5, 10, 20, and 50).  
(e) stated by [CÆSAR.BDD](#) version 1.7 on all 6 instances (1, 2, 5, 10, 20, and 50).  
(f) from place “aux16\_0” one cannot reach place “in4\_6”.  
(g) there exist 9 source places, e.g., place “in4\_6”.  
(h) there exist 64 sink places, e.g., place “out7\_1”.  
(i) stated by [CÆSAR.BDD](#) version 1.7 on all 6 instances (1, 2, 5, 10, 20, and 50).  
(j) stated by [CÆSAR.BDD](#) version 1.7 on all 6 instances (1, 2, 5, 10, 20, and 50).  
(k) stated by [CÆSAR.BDD](#) version 1.7 on all 6 instances (1, 2, 5, 10, 20, and 50).  
(l) stated by [PNML2NUPN](#) 1.3.0 on all 6 instances (1, 2, 5, 10, 20, and 50).  
(m) stated by [PNML2NUPN](#) 1.3.0 on all 6 instances (1, 2, 5, 10, 20, and 50).  
(n) the definition of Nested-Unit Petri Nets (NUPN) is available from <http://mcc.lip6.fr/nupn.php>  
(o) in the initial marking, some places have several tokens (the number of which depends on  $N$ ).  
(p) confirmed at MCC’2014 by Helena on all 6 colored instances, and by Lola and Tapaal on all 6 P/T instances.

## Size of the marking graphs

Parameter	Number of reachable markings	Number of transition firings	Max. number of tokens per place	Max. number of tokens per marking
$N = 1$	52 537 <sup>(q)</sup>	54 600 <sup>(r)</sup>	1 <sup>(s)</sup>	9 <sup>(t)</sup>
$N = 2$	?	?	?	$\geq 18$
$N = 5$	?	?	?	$\geq 45$
$N = 10$	?	?	?	$\geq 90$
$N = 20$	?	?	?	$\geq 180$
$N = 50$	?	?	?	$\geq 450$

---

<sup>(q)</sup> Computed by Alpina, and ITS-Tools at MCC'2013; confirmed at MCC'2014 by Helena on the colored net instance, and by GreatSPN, Marcie, PNMC, PNXDD, and Tapaal on the P/T net instance.

<sup>(r)</sup> computed at MCC'2014 by Helena on the colored net instance, and by Marcie on the P/T net instance.

<sup>(s)</sup> computed at MCC'2014 by GreatSPN, Marcie, PNMC, and Tapaal on the P/T net instance.

<sup>(t)</sup> computed at MCC'2014 by GreatSPN, Marcie, PNMC, and Tapaal on the P/T net instance.